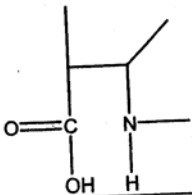
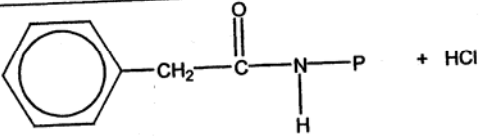

Question	Expected Answers	Marks
1a(i)	 <p>1 mark for each carboxylic acid correctly attached to the benzene ring</p>	2
a(ii)	Many/lots of monomers /molecules (accept long chain molecule) joined together; Small molecule/water/HCl is eliminated/ monomers have reactive groups at either end	2
b(i)	Permanent dipole – permanent dipole	1
b(ii)	Only <u>interaction</u> from C of carbonyl group on one chain to O on another ; C <sup>δ+</sup> correctly labelled on one chain O <sup>δ-</sup> labelled on the other chain.	2
c	M, repeating unit = 192 (1); No of repeating units = $\frac{384000}{192} = 2000$ (ecf)	2
d	3 from: (Sorting out plastics) then <u>melting/heating</u> and remoulding or gives a specific use; Incineration /burning <u>to produce energy/heat</u> ; Cracking/breaking down chains (to produce feedstock); Hydrolyse /converting back to monomers and <u>repolymerising</u>	3
		Total: 12
2a(i)	Order = 2; As [NO(g)] doubles and [O <sub>2</sub> (g)] kept constant rate quadruples/compares B and D or A and C	2
a(ii)	Order = 1; As [O <sub>2</sub> (g)] doubles and [NO(g)] kept constant rate doubles /compares A and B or C and D	2
a(iii)	Rate = k [NO(g)] <sup>2</sup> [O <sub>2</sub> (g)] =2marks 3 PARTS CORRECT=2 2 PARTS CORRECT=1 ecf from (i) and (ii)	2
a(iv)	3 ecf from (iii)	1
b	First order: conc vs time graph - descending curve (1); roughly constant half life (1); rate vs conc - straight line positive slope (1); through origin (1)	4
		Total : 11

Question	Expected Answers	Marks
3a(i)	$K_c = \frac{[\text{NO}]^2}{[\text{N}_2][\text{O}_2]}$ [products] / [reactants] = 1 powers = 1	2
a(ii)	Equilibrium lies over to the left / reactants side	1
a(iii)	$K_c$ will be higher; Equilibrium moves in favour of endothermic reaction/to take in energy;  Plus 1 from: Temperature in car engine is higher; Equilibrium has shifted to the right/ because NO formed	3
b(i)	$\text{Fe} + 2\text{H}^+ \rightarrow \text{Fe}^{2+} + \text{H}_2$ equation(1) balancing (no electrons) (1)	2
b(ii)	$\text{Fe}_2\text{O}_3 (1) \cdot x\text{H}_2\text{O} (1)$ dependent on a formula of iron oxide	2
b(iii)	2 from: painting/coat with zinc oxide; greasing/oiling/ waxing; underseal; galvanising/ coat in zinc; chrome plating	2
c	Any 2: Iron is a non renewable/ finite resource; Saves energy/extraction costs/non- renewable fuel; Named environmental issue - eg saves landfill space	2
d	Magnesium or zinc; Has a more negative electrode potential ;  Plus 2 from: will lose electrons (more readily); It is a stronger reducing agent; gets oxidised/reacts/corrodes in preference must be implied/ more reactive/ correct equation; replaced when worn away	4
e	2 uses 2 properties from (use should be appropriate to property) and different in each case. paper clip (1); - drawn into wires(1); construction (1); - strength (1); drill (1);-high melting point/ strong(1); cutlery(1);-resistant to corrosion/hard(1); underground pipes(1); -strength (1);	4
		Total: 22

4a	<p>4 from:  DNA consists of two (polynucleotide) chains/strands;  In a <u>double</u> helix;  *Each strand/chain/backbone is made of deoxyribose/sugar and phosphate groups (idea of a chain) NOT ribose;  *Each chain has <u>attached</u> bases;  *Bases linked by hydrogen bonding;  *Specific/complementary bases are paired/e.g. A-T C-G (between chains)  <b>Points labelled * can be gained from a <u>clearly</u> labelled diagram</b></p>	4
	Confusion with a chain of amino acids scores 3 max	
b	An amino acid would be missing	1
c	<p>1 mark for carboxylic acid group;  1 mark for amine group;</p> 	2
d(i)	ONLY Acyl chloride group circled	1
d(ii)		2
	1 mark	1 mark
		Total:10

**Clarification on the DNA answer-** They must indicate that at AT C and G are bases for the last marking point . **A pairs with T and C pairs with G is not enough** (which is likely to be the case if they have just drawn a diagram)

Question	Expected Answers	Marks
5a(i)	3 d <sup>9</sup>	1
a(ii)	It forms at least one <u>ion</u> /Cu <sup>2+</sup> in which the <u>d subshell/orbital</u> ; Is partially /incompletely filled	2
b	1 mark for both nitrogen atoms circled; 1 mark for all 4 O- circled	2
c(i)	6 x 10 <sup>-5</sup>	1
cii	6.00 x 10 <sup>-5</sup> x 63.5(1) x 1000/25(1) x 1000 (1) 152mg dm <sup>-3</sup> (1) <b>must be 3 sf for mark</b> allow ecf throughout	4
d	(Make up solutions) of known <u>concentration</u> of Cu <sup>2+</sup> ; <b>3 from:</b> of different concentrations; suitable range; Choose suitable filter; Calibrate colorimeter/zero <u>with water</u> ; measure absorbance/transmittance; Plot a calibration curve; read absorbance of sample; <b>plus</b> read value from graph  At least 2 consecutive sentences with only <b>one spelling mistake</b>	5 + 1
e	2 from: catalysts; variable oxidation state; paramagnetic; high density; high mp/bpt	2
		Total:18

